

FORENO.

TAPWARE MADE FOR NEW ZEALAND since 1969

REEF

Double Head Shower (1 Function)

REF71R

Congratulations on your purchase of this high quality product from Foreno Tapware.
Please read the following before installation and retain (along with your receipt) for future reference.

TECHNICAL SPECIFICATIONS

Suitable for Mains Pressures only

Minimum Pressure = 150kPa

Maximum operating Pressure = 500kPa* (As per NZ Building Code AS/NZ 3500.1)

Maximum operating Temperature = 65 deg. Celsius

For domestic use only.

INTERCHANGEABLE TOP OR BOTTOM INLET PLUMBING CONNECTION. (PRE-ASSEMBLED AS BOTTOM INLET CONNECTION)

CONFIGURATION

Mains Pressure systems Install as supplied.

Unequal Low systems Not suitable for this water pressure.

Equal Low systems Not suitable for this water pressure.

CONTENTS

- 1) Shower rail **(1)** with inlet/diverter assembly **(1A)**
pre-assembled as Bottom inlet connection
with lower bar **(1B)** attached
- 2) Upper Drencher bar **(2)**, with wall connection **(2A)**.
- 3) Adjustable Slider (handpiece holder) **(3)**
- 4) 1.5m shower hose with flow restrictor disc fitted
- 5) Shower drencher head **(4)**
- 6) Shower handpiece **(5)**
- 7) Wall fixing kit, includes:
plain wall fixing (7A), threaded inlet fixing (7B), spare grub screws.

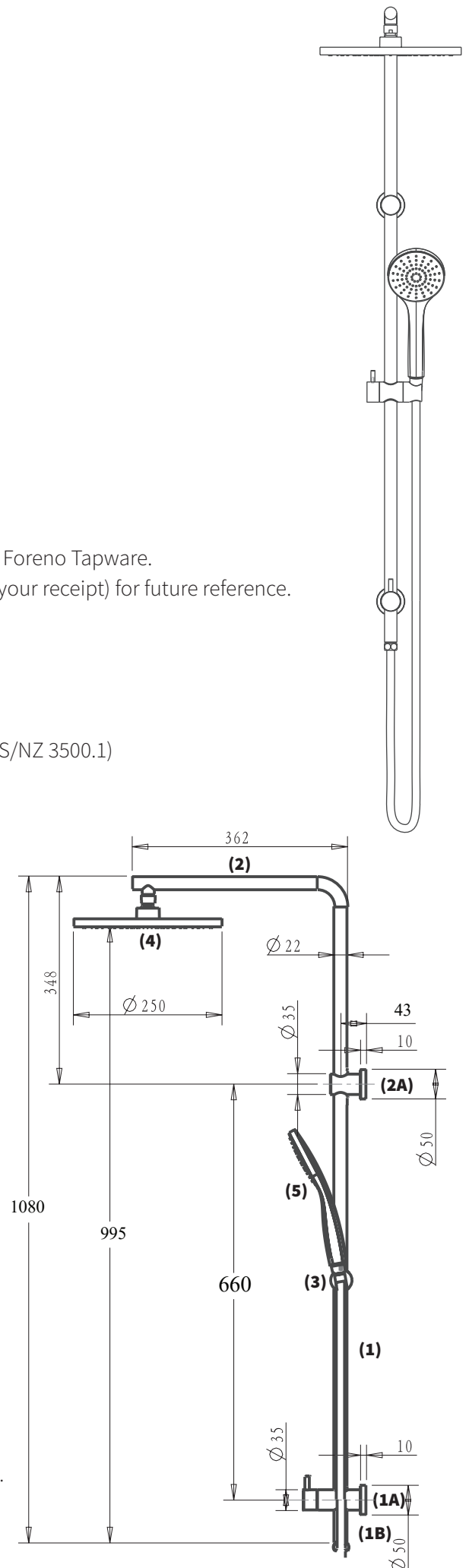

ATTACH PROOF OF PURCHASE HERE

INSTALLATION

***FOR PRESSURES EXCEEDING 500kPa INSTALL A PRESSURE REDUCING VALVE. THOROUGHLY FLUSH ALL PIPES TO ELIMINATE ANY REMAINING DIRT AND RESIDUE, AND INSTALL INLINE FILTERS. FAILURE TO DO SO MAY VOID THE WARRANTY. TO BE INSTALLED AS PER THE REQUIREMENTS WITH AS/NZS 3500.**

<p>1 FOR LOWER PLUMBING INLET**</p> <p>7MM DIAMETER HOLE FIXED TOP BRACKET</p> <p>FIXED DISTANCE 660mm</p> <p>SHOWER WALL OUTLET, 25MM DIAMETER HOLE (**REVERSE FOR UPPER PLUMBING INLET)</p>	<p>2 Apply teflon tape</p> <p>Screw threaded adapter to wall outlet then tighten firmly with spanner</p> <p>Push plastic wall anchor into drilled hole. Locate mounting adapter over hole, and screw firmly into place.</p>	<p>3</p> <p>Fit adjustable slider (3) onto shower rail (1). Fit upper drencher bar (2) onto shower rail (1) with grub screw aligned to back, & firmly tighten grub screw (B). Fit onto wall by gently pushing onto upper fixing (7B) and lower inlet connection (7A). Tighten m5 grub screws (E) with allen key to fix into place.</p>	<p>MAINTENANCE AND CARE</p> <p>Should only be cleaned with mild liquid detergent or soap.</p> <p>Do not use cream cleaners, as they are abrasive. The use of unsuitable cleaning agents may damage the surface. Any damage caused in this way will not be covered by warranty.</p> <p>DIVERTER OPERATION</p>
<p>4</p> <p>Install the shower head (1) onto the top tube (2) by screwing into place. Ensure pre-installed rubber washer and flow regulator are in place (5). Screw the shower hose (3) onto the hand piece. Ensure pre-installed rubber washer is in place (6).</p>	<p>5</p> <p>Connect the shower hose (1) to the bottom tube (2) as shown. The installation is now complete. Turn on water supply to check for leaks.</p>	<p>If upper inlet connection is required, loosen the 3x grub screws (A, C, D), and pull apart. Attach inlet/diverter assembly (1A) to upper drencher bar (2) & tighten grub screw (A). Attach wall connection (2A) to shower rail (1) and lower bar (1B). Tighten grub screws (C,D), and fit to wall fixings as above.</p>	

Note: This shower has a WELS certified flow restrictor fitted between the shower hose and wall elbow connection. If you want a greater flow, remove this disc but note that this will not give a WELS 3-star water rating anymore.

WARRANTY

PLEASE CALL US BEFORE REMOVING OR UNDERTAKING ANY REPAIR WORK.

Please refer to our website for warranty information: www.foreno.co.nz/warranty

In the unlikely event that this product fails during its warranty period, phone our Customer Service team immediately on 0508 FORENO (0508 367 366) – as unauthorised removal of the product may void the warranty.

CARE AND MAINTENANCE

SHOULD NOT BE CLEANED WITH ACIDIC, CAUSTIC/ALKALINE, ABRASIVE OR CITRIC CLEANERS.

A soft, damp cloth is recommended for cleaning (Not a Micro fibre cloth). Mild soap solutions can also be used on occasion.

See website for full care instructions: www.foreno.co.nz/tapware-care-instructions/